

HUSTLER

Journal of the kit car élite

no. 10



Issue No 10. I can't really believe I have Managed to last so long. We are into our third year, and still have a healthy and growing membership. Many of you have been with the club from the beginning. But as I had expected with the third year approaching quite a few of the original members have now sold their cars. When you do pass on your Hustler try to persuade the new owner to join the club or just drop me a line in an attempt to keep track of the various cars. It would be interesting to know what happens to ageing Hustlers when they die.

We have an average membership of about 50 which tends to rise to about 80 by the end of each year, then drops back to about 50 at the start of the next year. That is quite a lot of cars disappearing each year, I wonder what happens to them?

Right, thats the winter out of the way. Perhaps now we can all look forward to a few months of nice sunny weather. I havent done a lot to my car as I am very reluctant to venture into the Garage during the cold winter evenings.

One thing that did happen was, my other car had to go into the local Citroen agent for what turned out to be a prolonged repair. The day after it went into the garage and we were using the Hustler for transport the heaviest snow of the winter fell and stayed for three weeks. I must admit the Hustler is not the most ideal car in the snow, and with a trailer hitched on the back you might as well stay at home.

Any articles for issue No 11 could I please have them in by the last week in JUNE.

Membership Nos. up to 078 now due for renewal.

I have sold the Hustler Owners Club Headquarters but I have'nt moved yet. I will let you all know when I have a new address, in the meantime you can still reach me here at Aldershot.

I look forward to seeing as many of you as possible at Stonleigh at the end of the month. I will try to get there for both days if at all possible. I have booked the club spot so let us hope the weather is fine.

Details to in this issue of this years Hustler at Home. A bit more notice this year, I am afraid I boobed a bit last time it was a bit short notice. All club members are invited with a Hustler or not.

I look forward to seeing you all sometime during the summer. I am sure the weather just can't be as bad as last year. Can it?.

Newsletter No11 due for issue 1st July.

Fred

April 26 -27th NATIONAL KITCARS & SPECIALS SHOW
Royal Showground, National Agricultural Centre
Kenilworth, Warwickshire.

This is the first and probably the largest Kitcar Show in the calendar. Well worth a visit.

I have booked us a Club Spot. Therefore if you are arriving in a Hustler bring it into the Showground by the Machinery Gate entrance.

Admission. £2.50 per person per day.

If you wish to camp, the cost is £6.00 per person for the weekend.

Bookings. Special Events & Promotions

27 Warwick Road

Kenilworth. Warwickshire CV8 1HN

May 17 -18th DONCASTER CUSTOM MOTOR SHOW
Doncaster Racecourse Exhibition Centre.

Mainly a Custom Car Show but becoming more popular for Kit Car owners.

Camping Available.

Info.

Stuart Lovell
22 Newby Cres,
Alverly Est.
Balby
DONCASTER.

June 21- 22nd KITCAR SHOW

Newark & Nottinghamshire Showground.

Another annual car show, but one which gets better as it grows.

Also very much cheaper than Stonliegh. Kit car and driver get in free, only passengers pay and less than Kenilworth. Camping is also free for everyone and no need to book.

I will book us a club spot here, and hope that this year I will actually make it Newark.

The organisers are also looking for someone to enter the Miss Kit Car competition .

ORGANISERS. Unique Promotions

2 Nursery Close, Saxilby, LINCOLN LN1 2JD.

JULY 5 -6th Note !!!! JULY 5-6th This is the one. The one you have
all been waiting for.

THE 1986 ANNUAL HUSTLER AT HOME.... Park Farm, COMPTON VERNEY

Different format for this years get together. This years Hustler
at Home will coincide with the local festival and fete which is
to take place at Park Farm. Mr and Mrs Towns thought it would be
a good idea for us to attend on the same weekend. It should be a
very enjoyable weekend with lots happening and plenty of interest
for everyone including the children.

There is plenty of room for us all to camp together as usual. We
can also still have our Bar B Que on the Saturday evening so bring
your goodies for the picnic.

We will not be going for our Pub run this year on the Sunday morning
I think we will be to busy enjoying the show. There is bound to be
a beer tent in situ. during the weekend and we won't have to drink
and drive.

All club members are welcome, with a Hustler or not.

You can arrive any time from the Friday evening on.

I have started saying special prayers for good weather.

July 12 - 13th EASTERN COUNTIES TRANSPORT SPECTACULAR
Suffolk Showground. Bucklesham Road. IPSWICH.

A new show for this year. From the 'Blurb' I recieved from the
organisers it looks like it promises to be a very good weekend.
Caravan and camping facilities available.

Enquiries: C M Smith
87 Worthington road.
Fradley
LICHFIELD. Staffs.

July 19 - 20th NATIONAL SPORTSCAR WEEKEND.
Park Farm, Compton Verney. Wellesbourne. Warwick.

Should be a good attendance at this one. Apart from the fabulous
venue, several car clubs are holding events in the central arena,

there promises to be helicopter rides, and a Bar B Que on the Saturday night. All this coupled with the hottest weather of the Summer (???) should make it a great weekend.

Admission £2.00 per day (children under 14 free),,Camping £1.00 for each adult.

Aug 9 -10th NATIONAL COMPONENT CAR SHOW
Sandown Park. Esher. Surrey.

I attended a meeting with the organisers of this show to see if some of the problems of last year could be overcome.

This is the outcome of this discussion.

Major club site will be in the centre of the racecourse.

Entrance fee to the club area for component/kitcars occupants nil, entry to the exhibition site £1.50 per head. (HALF PRICE)

Club members attending with non kitcars MUST use the main car parks, but can still obtain half price admission on production of their Car Club Membership card at the exhibition entrance NO1. (this gate only).

Camping facilities available but must be booked in advance.

More info. The Clans, Stonehill Road, HEADLEY DOWN, Hants GU35 8ET.

Do you want
Sleepless nights
No money
No skin on your knuckles
No spare time
To amuse the neighbours
To pester your friends
Then build a HUSTLER
And, if you want to ...
Cause a stir wherever you go
Make friends with the elite
Get stared at by strangers
Be waved at by people in the street
Barked at by dogs
Laughed at by the unconverted
THEN DRIVE A HUSTLER
But if you want an inconspicuous
Getaway car to rob a bank
Try a Rolls Royce
But Don't try a HUSTLER !

48, Meadow Way,
Walton,
STONE,
Staffs.
ST15 0JP.
Tel: Stone (0785) 817866.
27/3/86

Dear Trevor,

First of all let me apologise for sending my subscription so late. Please find a cheque of £4 enclosed. Also the text enclosed will probably be too late for inclusion in the next N/L. Sorry. Nevermind.

WINDSCREEN WIPER Parking Position

I've noticed on a couple of Hustlers that the windscreen wiper is parked on the drivers side of the screen. I don't know if this is desired, but if not there is a simple way of changing the park position so that the wiper will park on the nearside of the screen. All that has to be done is to separate the nylon/plastic gear wheel from the spindle (it's just a push fit) and rotate it through 180°. Then re-join them by pushing them together so that the spindle flange locates with the lugs on the gear wheel. See diagram below:-

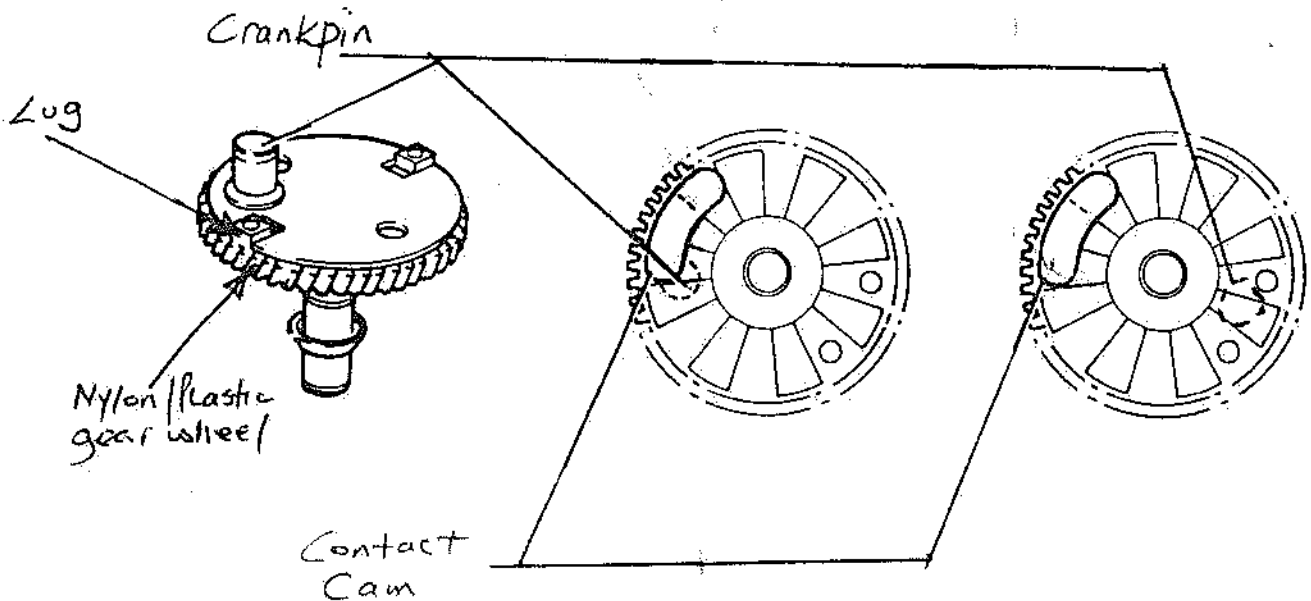

Alternatively the windscreen wiper box can be rotated through 180°. See diagram below:-

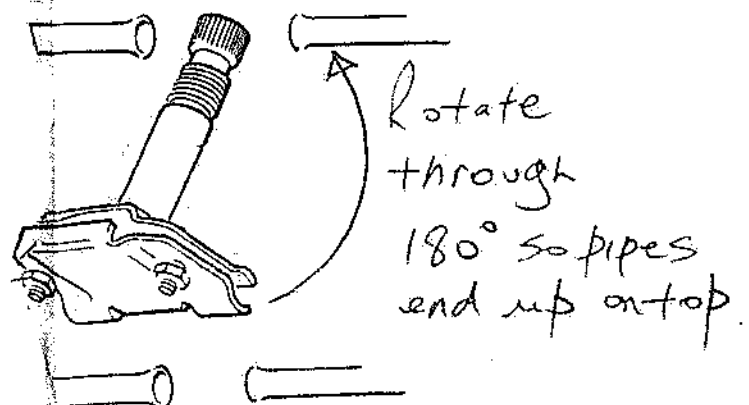

Rattling Windows!!

I've come across a way of cutting down the rattling but as yet have not completely eliminated it. The company 'Selotape' market a draft excluding kit consisting of 6 strips of plastic moulding with a nylon 'brush' arrangement located in a channel down one side. This I have fitted to the top and angled pieces of channelling of the aluminum. See diagram below :-

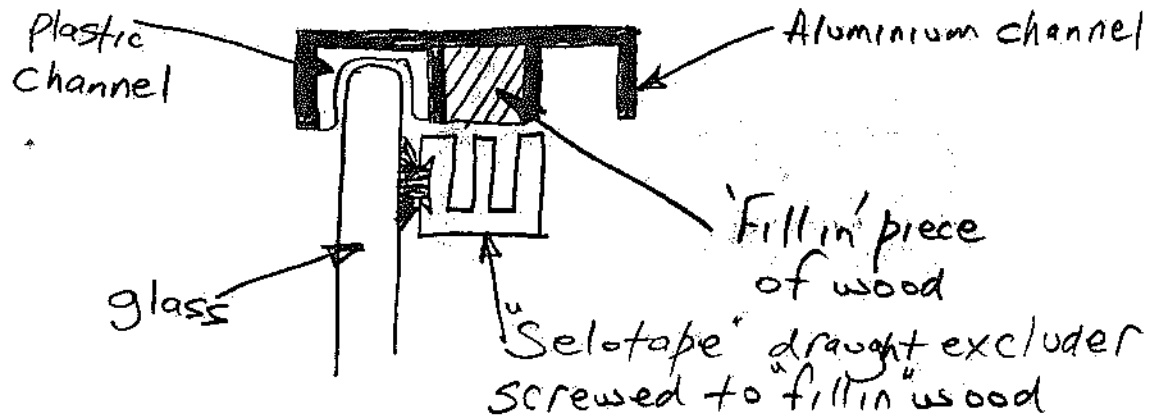

I see from Kit Car magazine that the dates for Kenilworth this year are April 26th & 27th. All being well we should be there on the Sunday. It doesn't say any thing about admission for Kit car and driver being free and what is the procedure for getting into the Show with my car?

In reply to Martin Guinan's comment in the last N/L —Yes I thought a wooden 6 would be under powered and it is certainly alot cheaper to build. On initial costing against a metal and fibre glass 6 it worked out to be approx £600 cheaper at the time, plus the fact it is easier to do modifications when you have control over cutting out the shapes from the wood. I'm looking forward to seeing how someone else has modify a wooden 6 to accomodate a larger engine.

Hoping to see you on the 27th April,

Yours Faithfully,

Keith

Keith Sharp Stone Staffs

I recieved this wiring diagram from Peter Bockh.
 It looks as if it could be of assistance when it comes to wiring
 your pride and joy.

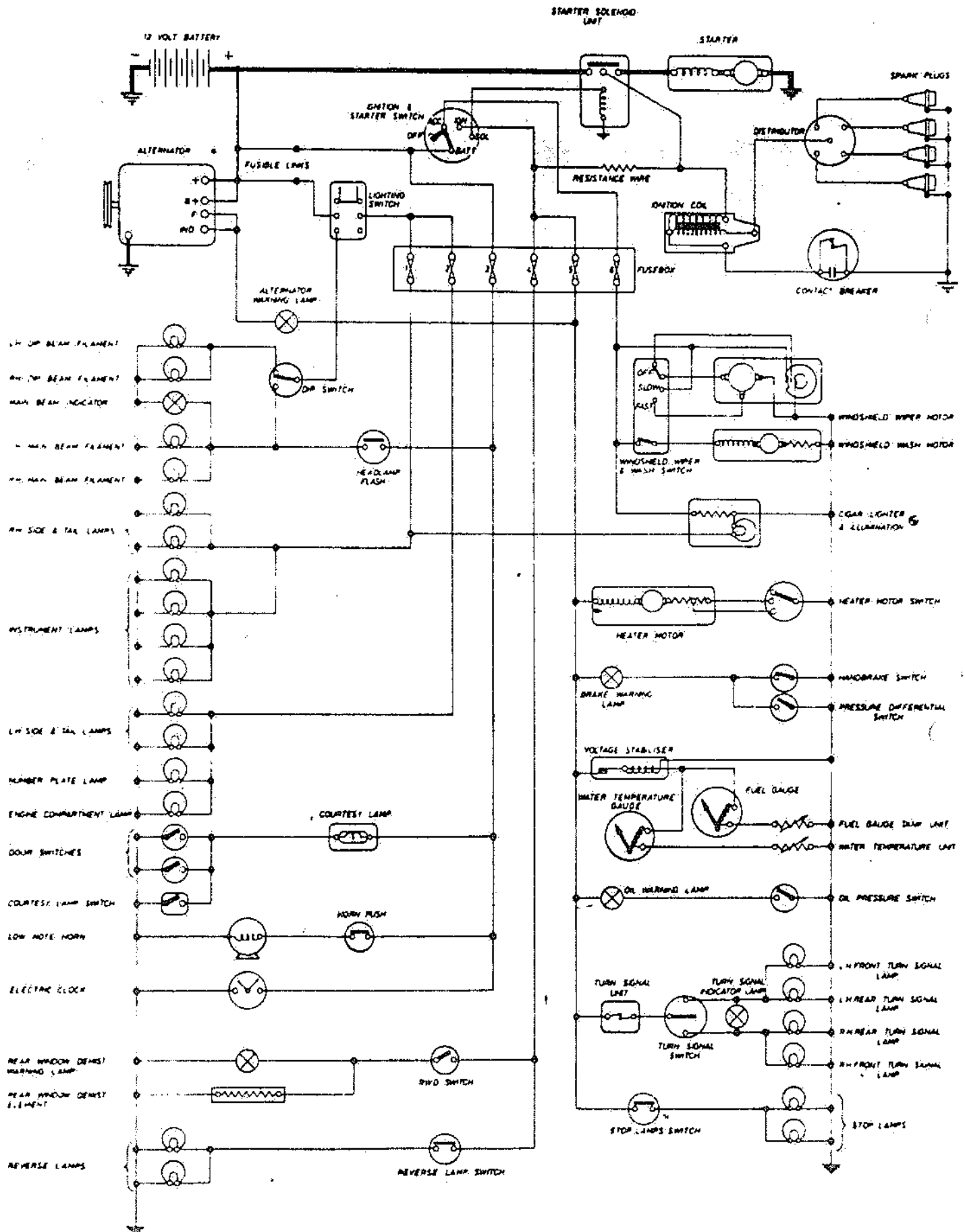

FOR SALE

Hustler Rear Window, complete with Hinge.

Brand new. £30.00. ono.

contact. Angela Shepherd 27 Redhatch Drive. Earley. READING.
Telephone 0734 872661.

11" Weller Wheels New still in boxes.
total of seven wheels. £80.00 the lot.

contact. David Browne 3 Benhilton Court, Woodside Road.
SUTTON, Surrey Tel. 01 641 1418.

I havent included a list of cars for sale as it seems rather pointless. Most members have either got cars or are in the middle of building one.

Instead I keep a description of the cars for sale by the phone for when I get any enquiries. By the way why not bring the car to Stonleigh and put a 'for sale' notice on it on the club pitch.

I noticed the magazine article regarding the rubber timing 'chain' and I can certainly vouch for it. I did mention it when I wrote to you before - it is very easy to fit and twelve months/6 months later has caused no problems at all. If anyone is changing their timing chain it is worth doing.

The article by Keith Sharp was most interesting, there is no substitute for c.c.'s no matter what you do to the engine. You may recall that I modified my 1000cc engine to extract the last drop of power out of it but it does still lack power at lower engine revs. I did get it properly tuned on a rolling road and the engine now develops 58bhp at the wheels which is not at all bad but unfortunately its at 5,800 rpm. Not too much use in top gear as it works out at 90+mph, but it can be used to the full in lower gears where the effect as it comes 'on cam' is quite dramatic. In case anyone is interested and does not want to go to the trouble of major modifications to fit a larger engine I did the following:-

- Stage 2 head (large inlet valves)
- water heated inlet with 1½ carb.
- Cooper exhaust
- modified 731 camshaft

This does have the advantage of overall low cost comparatively but does not produce a great deal of power below 2500rpm.

The only real answer is a bigger engine. The engine tuner at Marshalls of Cambridge has been quite impressed with Avonbar's products, their 1400cc produces plenty of power at all revs. In fact it should compare well with the 1750cc but you can, I understand, get poor conversions from some suppliers.

Incidentally, my modified 1000cc managed to come back from the last Hustler at Home at 60mph+ or 70 on dual carriageway and managed to average 34mpg!

Having now passed its second MOT without much difficulty the MOT tester did make the remark that Mini steering racks are notorious for wear if fitted with wider wheels. My rack will need replacing in the next 12 months so if anyone is in the process of building it could well be worth putting in an exchange rack from the start.

Andy Elvin, Lowestoft.

I SIZES Chest or bust size in inches, 2" size steps

- | | | | | | | | | | | | | | | | |
|--------------------|----|----|----|----|----|-----|----|-----|----|-----|----|-----|----|-----|----|
| 1. Inches | 22 | 24 | 26 | 28 | 30 | 32 | 34 | 36 | 38 | 40 | 42 | 44 | 46 | 48 | 50 |
| 2. Ladies' Bust | | | | | | 10 | 12 | 14 | 16 | 18 | 20 | 22 | 24 | 26 | 28 |
| 3. Men's Collar | | | | | | 13½ | 14 | 14½ | 15 | 15½ | 16 | 16½ | 17 | 17½ | 18 |
| 4. Children's Ages | 2 | 4 | 6 | 8 | 10 | — | — | — | — | — | — | — | — | — | — |

A. LOOK AT THE PRICE GUIDE

Item	Price Guide	
	From	Average
T Shirts	1.95	4.95
Sweatshirts	4.95	8.95
Sports Shirts	6.95	12.95
Men's Shirts	6.95	10.95
Ladies' Blouses	6.95	10.95
Overalls	19.95	24.95
Jogsuits	19.95	24.95
Tracksuits	24.95	29.95

04868 7068

DIAL A T-SHIRT

RING
A3 GREEN

SHIRT BAR

MILFORD

OPEN
11am-9pm

DIAL A PRINT

04868 7068

The address for those who wish to visit the shop is:

3 New Road, MILFORD. Surrey.

On the A3 next to the 'White Lion Pub'

Club Badges as on the right.

Cloth, Black & White.

£1.20 each.

Club Keyrings as on the left. 30. pence each.

Cheques made payable to 'Hustler Owners Club'.

Send to :

Trevor Faithfull
4 Lodge Close
Church Lane East.
ALDERSHOT
Hants GU11 3TA

